

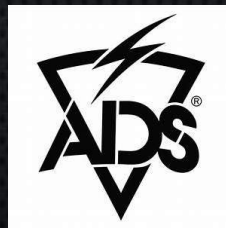

CAPABILITIES

OF HHI CORPORATION



HHI CORPORATION FACTS

- IN BUSINESS 47 YEARS
- QUALIFIED, HIGHLY EDUCATED STAFF
- \$250 MILLION AGGREGATE BONDING
- DIVERSE CLIENTELE
- 15 OUTSTANDING PERFORMANCE EVALUATIONS
- NEVER LATE ON A PROJECT IN COMPANY HISTORY
- 54 ACRES OF HHI PROPERTY
- 90,000 SQ. FT MANUFACTURING SPACE



Located in beautiful Ogden, Utah



54
Acres



90,000 Sq. Ft Total
Includes Storage
& Office Space



Paint & Blast Booth



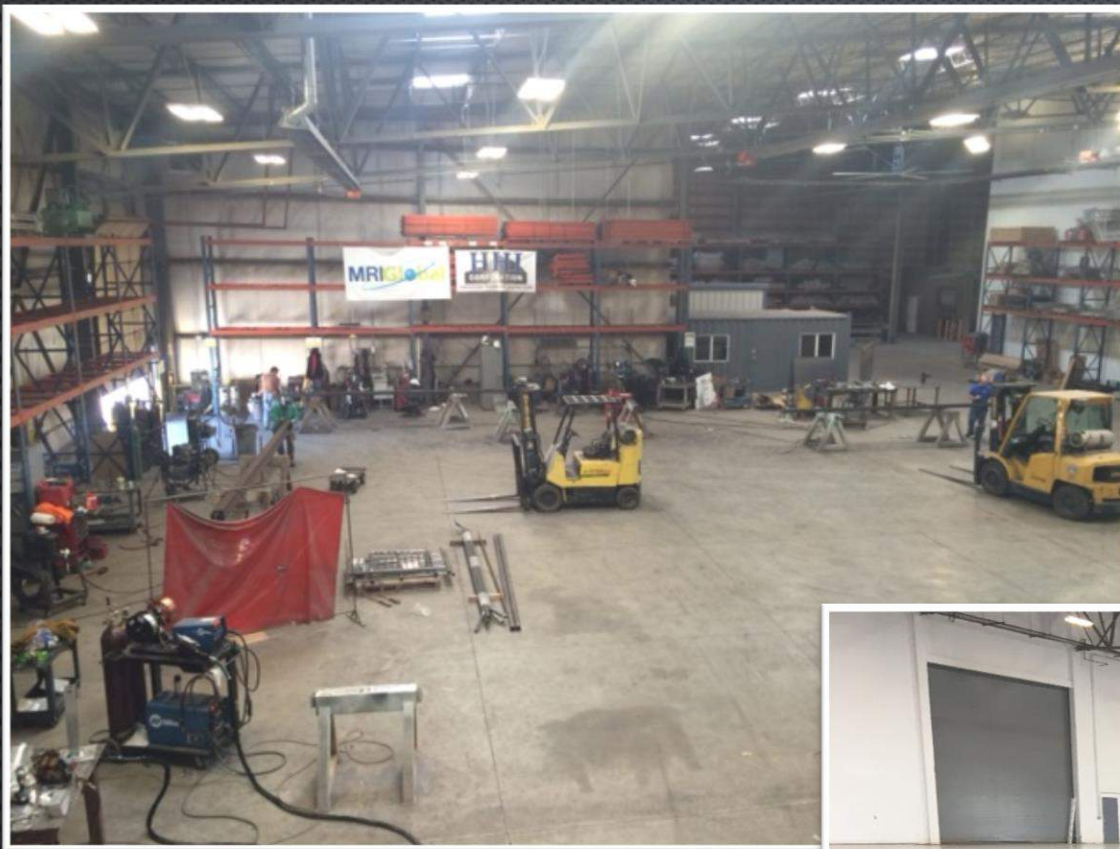

90,000 Sq. Ft
Manufacturing Space

SHOP CAPACITY



ADS Contracts w/HHI

- C-40 STANDS @ SCOTT AFB
- C-17 ENGINE STANDS @ DOVER, MARCH, WRIGHT PATT, EDWARDS AFB
- UH-60 STANDS @ MISSISSIPPI ARMY NATIONAL GUARD, GULFPORT
- HIGH LINE DOCK @ REDSTONE ARSENAL
- UUV TRAILER @ SUBDEVRON 5



Why Sale HHI Products?

- HIGH DOLLAR AMOUNT
- MARK UP IS 20% +
- RUN THROUGH TLS CONTRACT
- PRE-APPROVED BY DLA
- PROCESS IS VERY FAST AND EASY
- PRODUCT IS BETTER QUALITY THAN COMPETITORS (FLEXIBLE LIFELINE, SPIKA, CVI)



Examples of bad stands:







Competitors stand that they dislike!



HHI's stand to replace competitors





C-40 ENGINE
MAINTENANCE
STANDS

C-40 MAINTENANCE STANDS



Nose Stand



Section 48 Stand



Wing Stand



Wing Stand



Winglet Stand



Lights/Electrical/Air





C-17 ENGINE
MAINTENANCE
STANDS

C-17 MAINTENANCE STANDS



McChord AFB



Wright Patt AFB





UH-60
MAINTENANCE STANDS

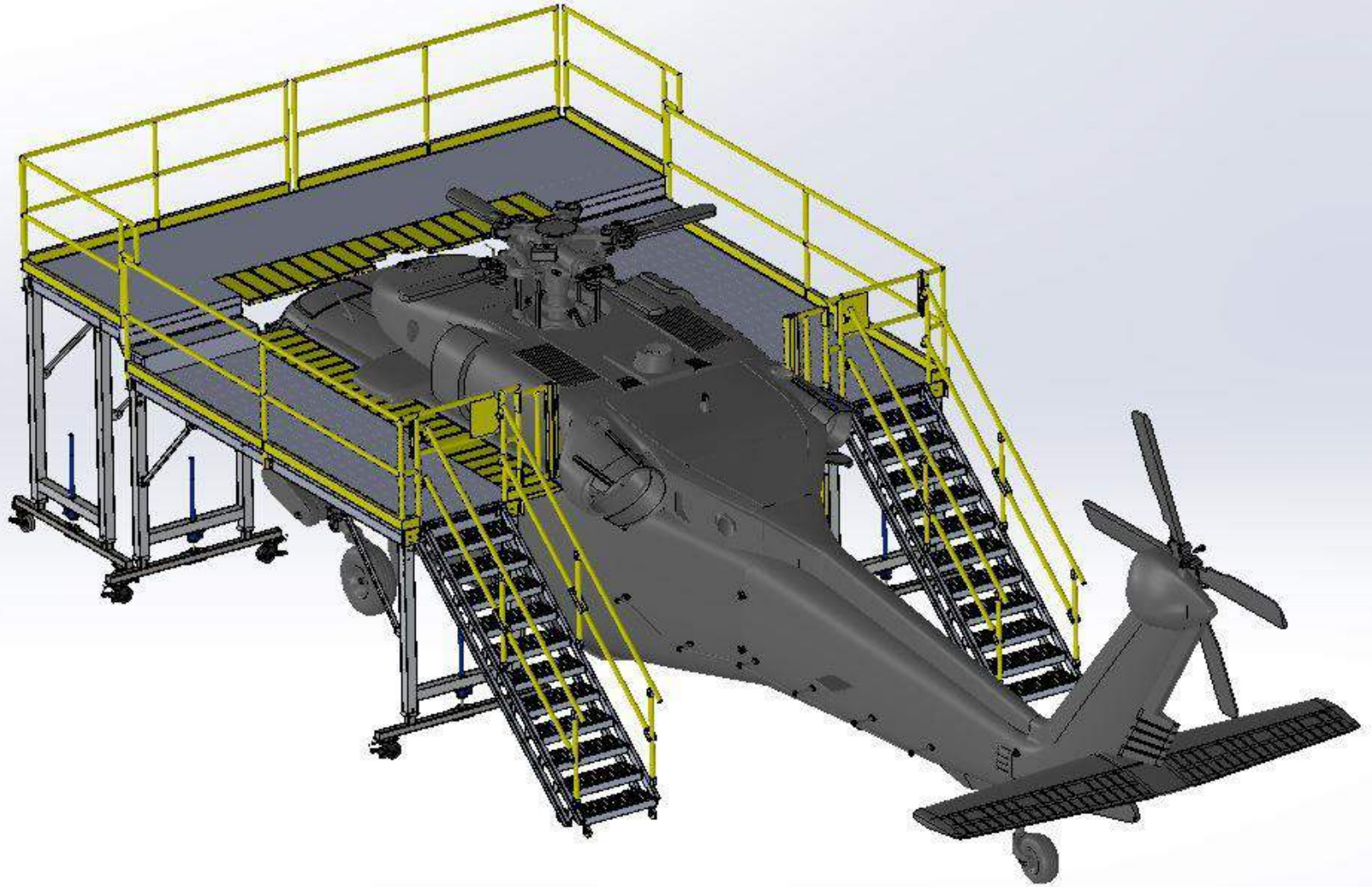



UH-60 Gulfport



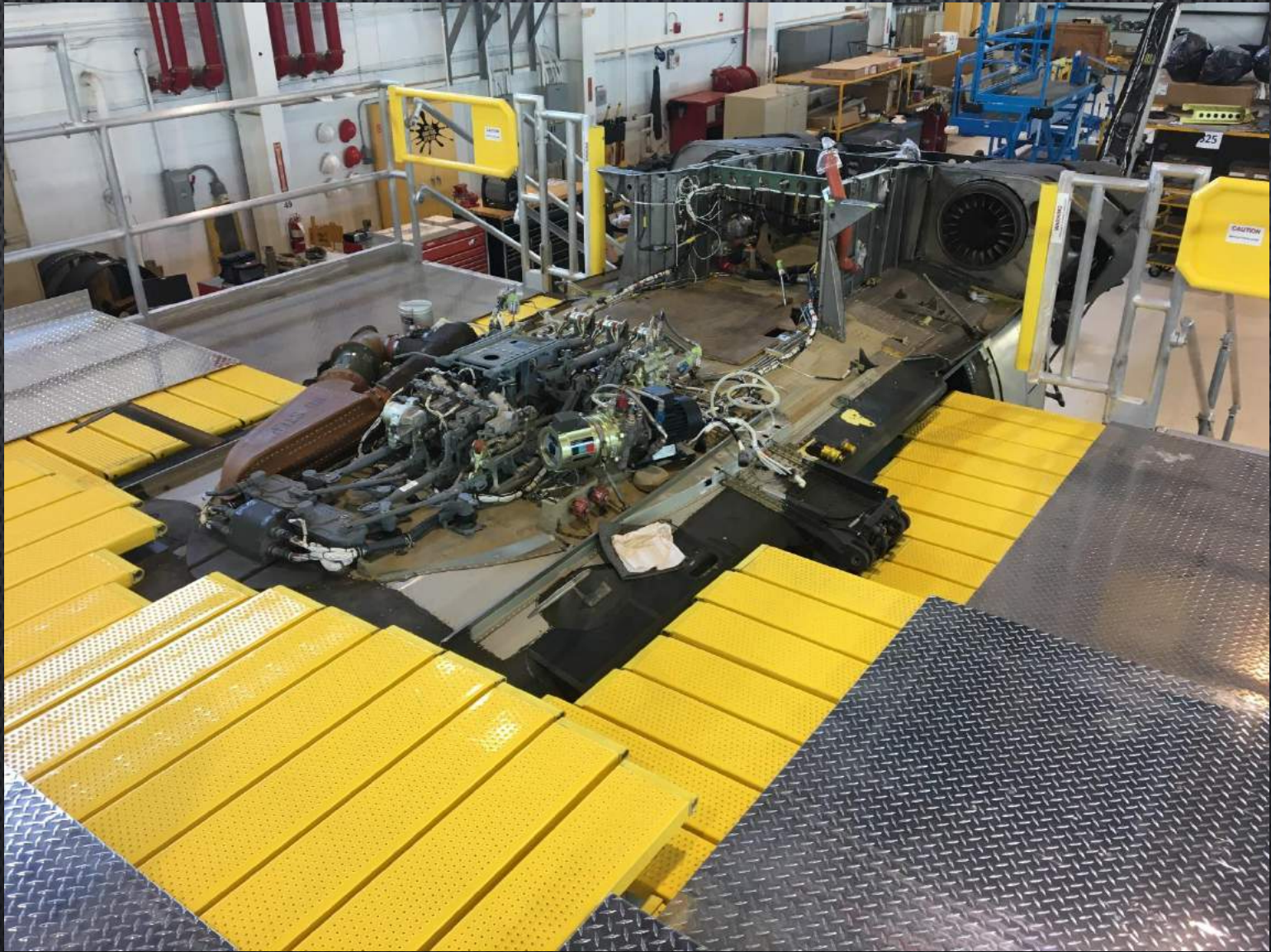





HIGH LINE DOCK

HIGH LINE DOCK

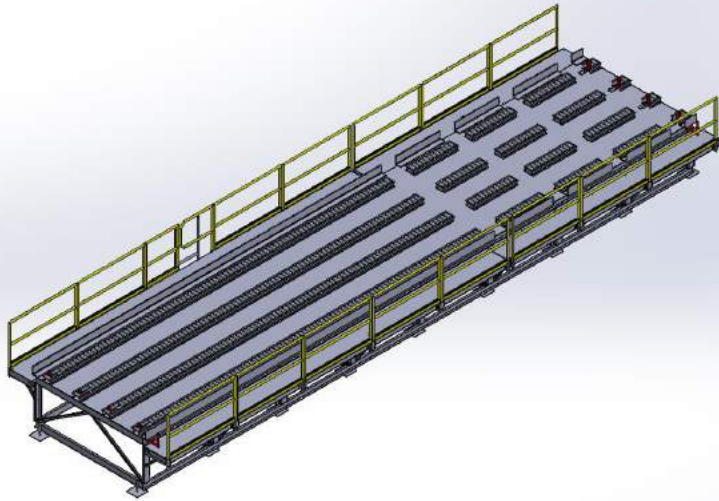



HIGH LINE DOCK



UUV TRAILER

UUV TRANSPORT TRAILER

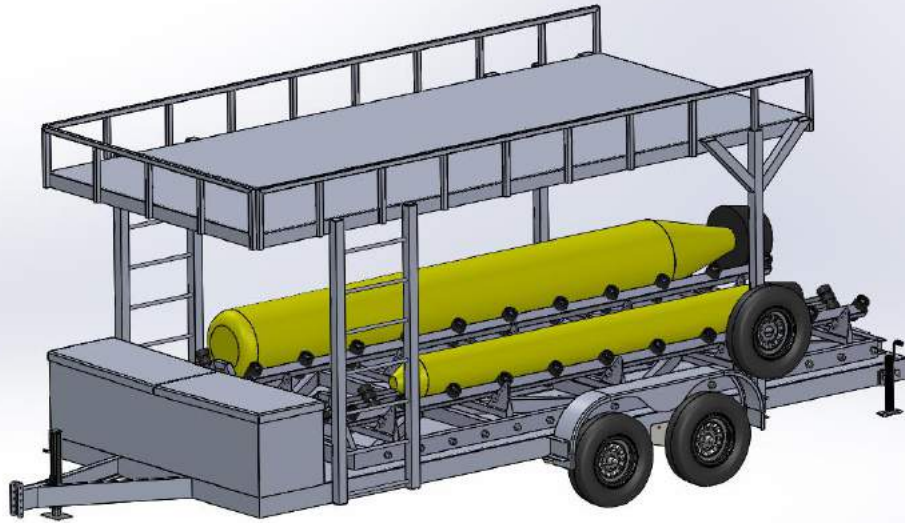



UUV TRAILER



UUV TRAILER



SAMPLES OF WORK

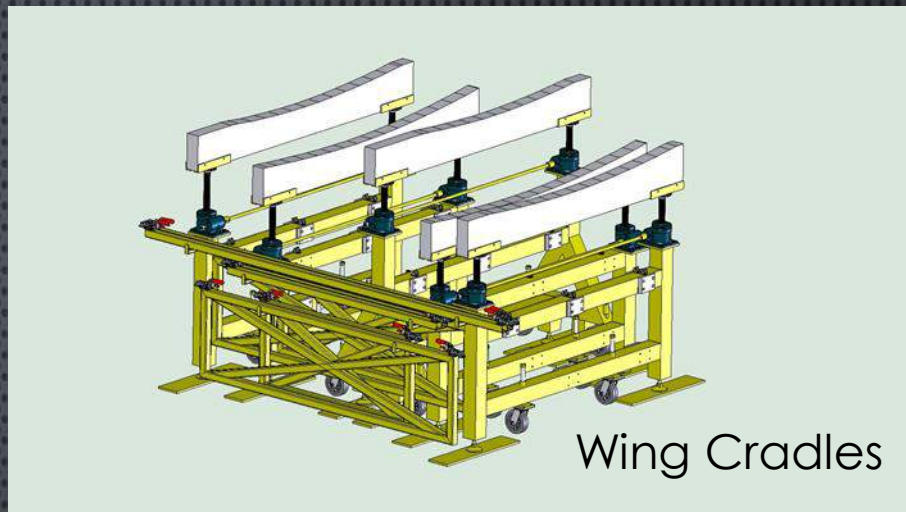
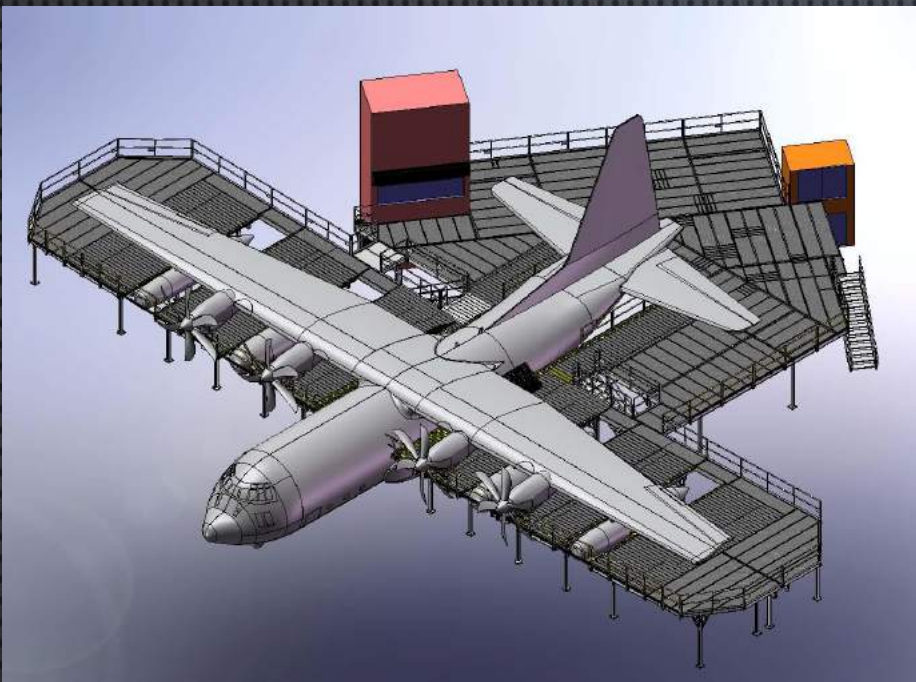

Wing Cradles

C-130 STANDS



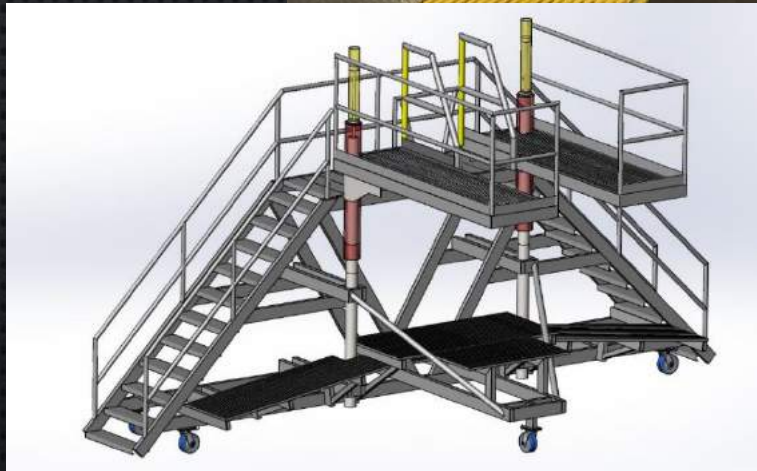
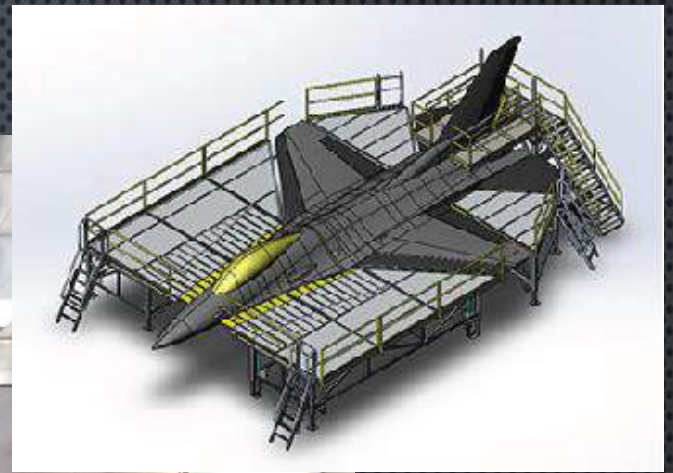

F-16 MAINTENANCE STANDS

UNIVERSAL MAINTENANCE STANDS



HOTTEST TRAILER

Holds 4 Brake Assembly Cases

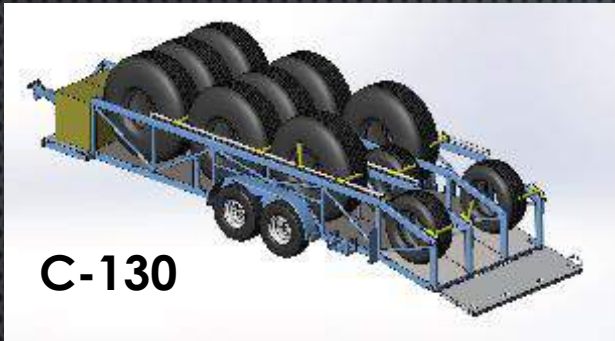

C-130

Universal Aircraft
Tire Transport Trailer

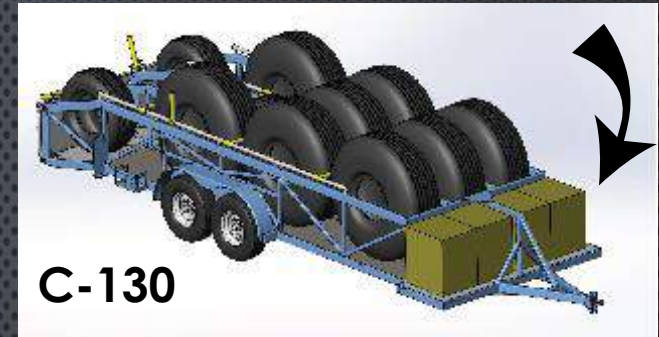

C-130



C-17



C-17

- Carry up to 6,000 lbs.
- Locks each tire into place
- Adjustable chocks to fit size of tire
- Tailgate doubles as a ramp



C-17

- HOLDS:
- 2 Complete Sets of C-130 tires
 - 1 Complete Set of C-17 tires
 - ½ Set of C-5 tires

- Extremely efficient
- Easy to use foot pedal
- Hydraulic lift
- Load of 6 tires
- Lifts 24" off the ground

Hottest! New Cutting Edge Technology

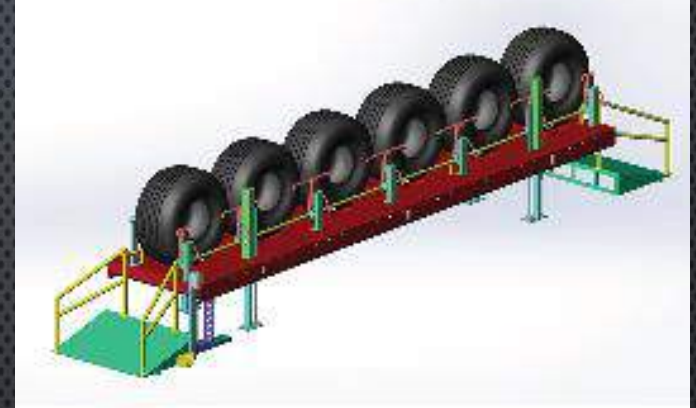

Tire Work Station

"The new machine alleviates the need to work bent at the waist for almost the entire break-down of the wheel," said 1st Lt. Naomi Ballard, 62nd Aircraft Maintenance Flight commander. "It's also a safer way to work because the stand holds the tires upright, which eliminates the possibility that the tires will fall over while my guys are working on it."

Since the wheel and tire machine arrived, the capability of the four-man maintenance shop to safely and efficiently rework wheel and tire assemblies has increased insurmountably. Technicians maintain assemblies on 48 of McChord Field's permanently assigned C-17 Globemaster III aircraft, equating to roughly 125 assemblies each month with an average annual inspection rate of 1,300 units.

"The machine is really turning out to be a good investment for McChord and the Air Force," said Owen. "We are easily able to turn out 12 wheels in a four-hour period."



AGE Equipment & Tripod Trailer



McChord AFB



PAINT AND BLAST BOOTHS



INFECTIOUS DISEASE CONTAINERIZED BIO-CONTAINMENT SYSTEM

CONTAINERIZED BIO-CONTAINMENT SYSTEM (CBCs)

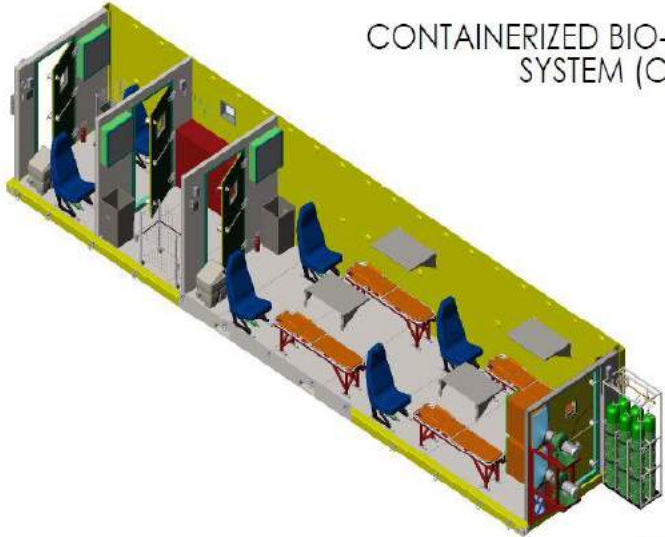



ROTARY WING
MAINTENANCE STANDS



UH-60
BLACK HAWK

UH-60 Wrap Around Stand

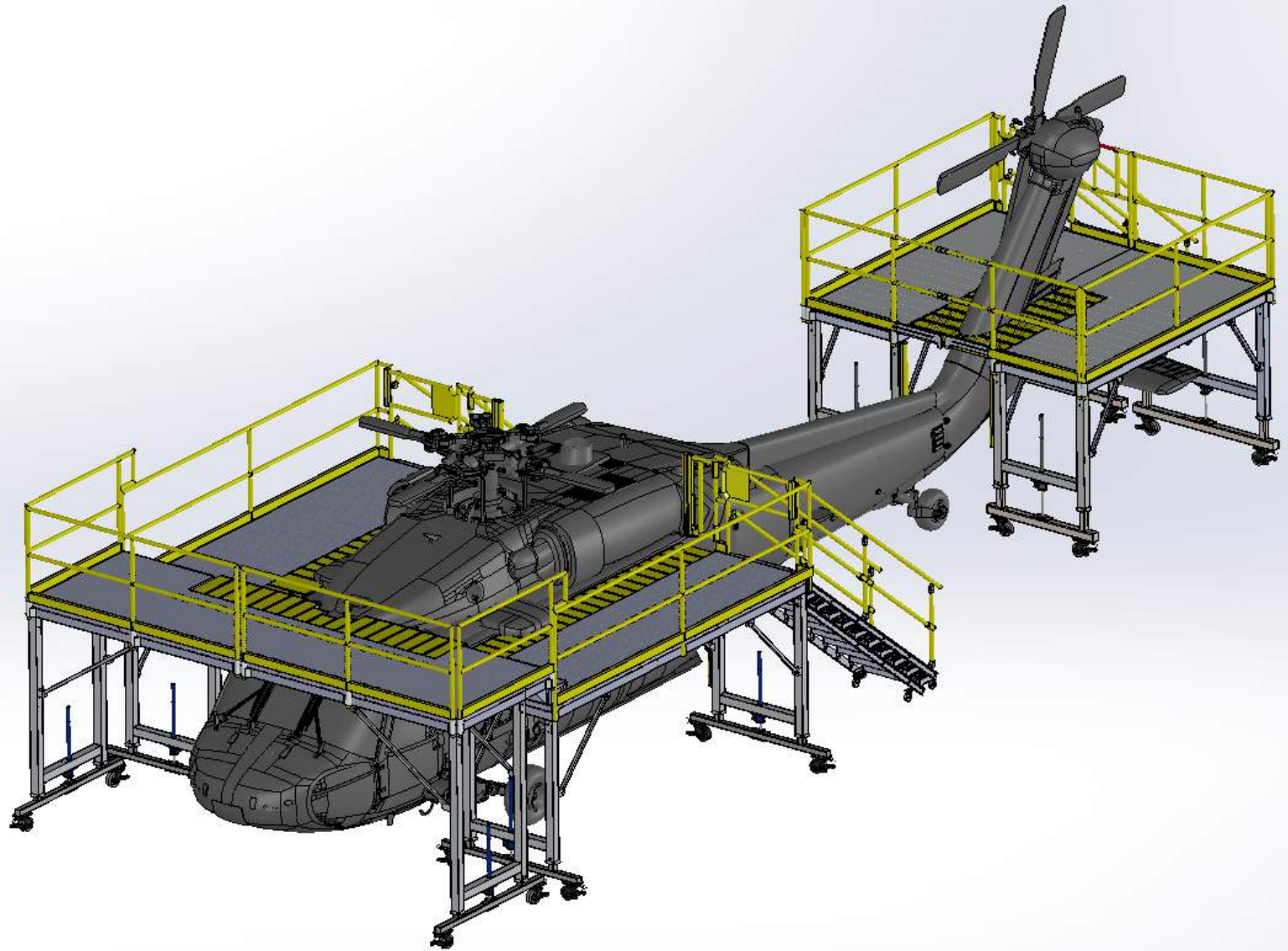

UH-60

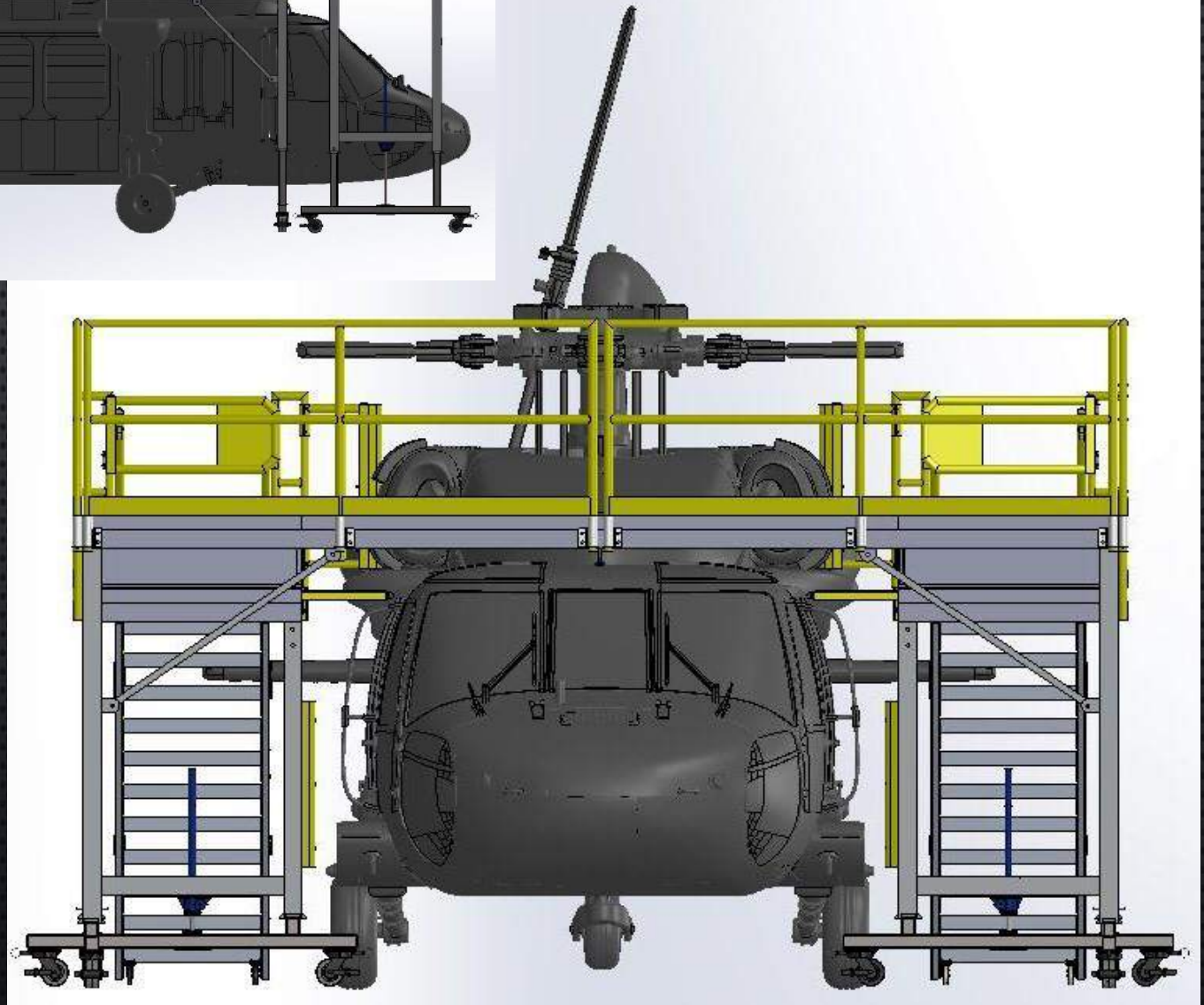
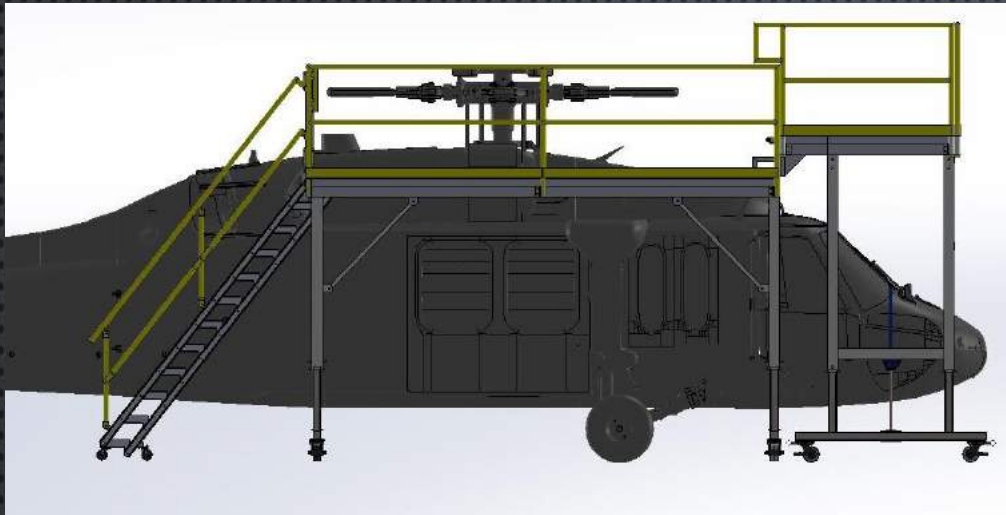

UH-60 TAIL STAND



UH-60 Universal Stands



UH-60 Universal Stands

Blade Trailer

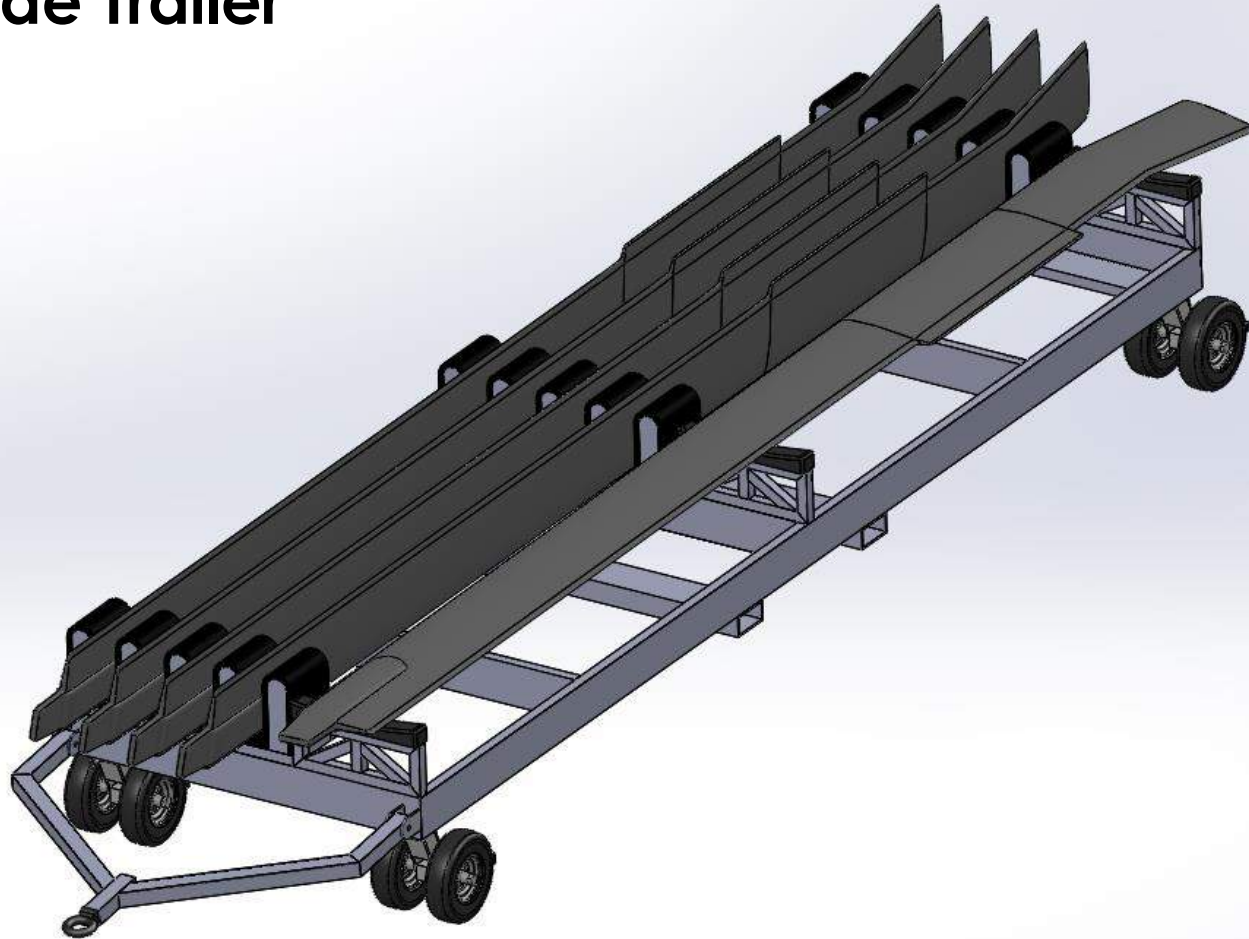



CH-47
CHINOOK

CH-47 CHINOOK

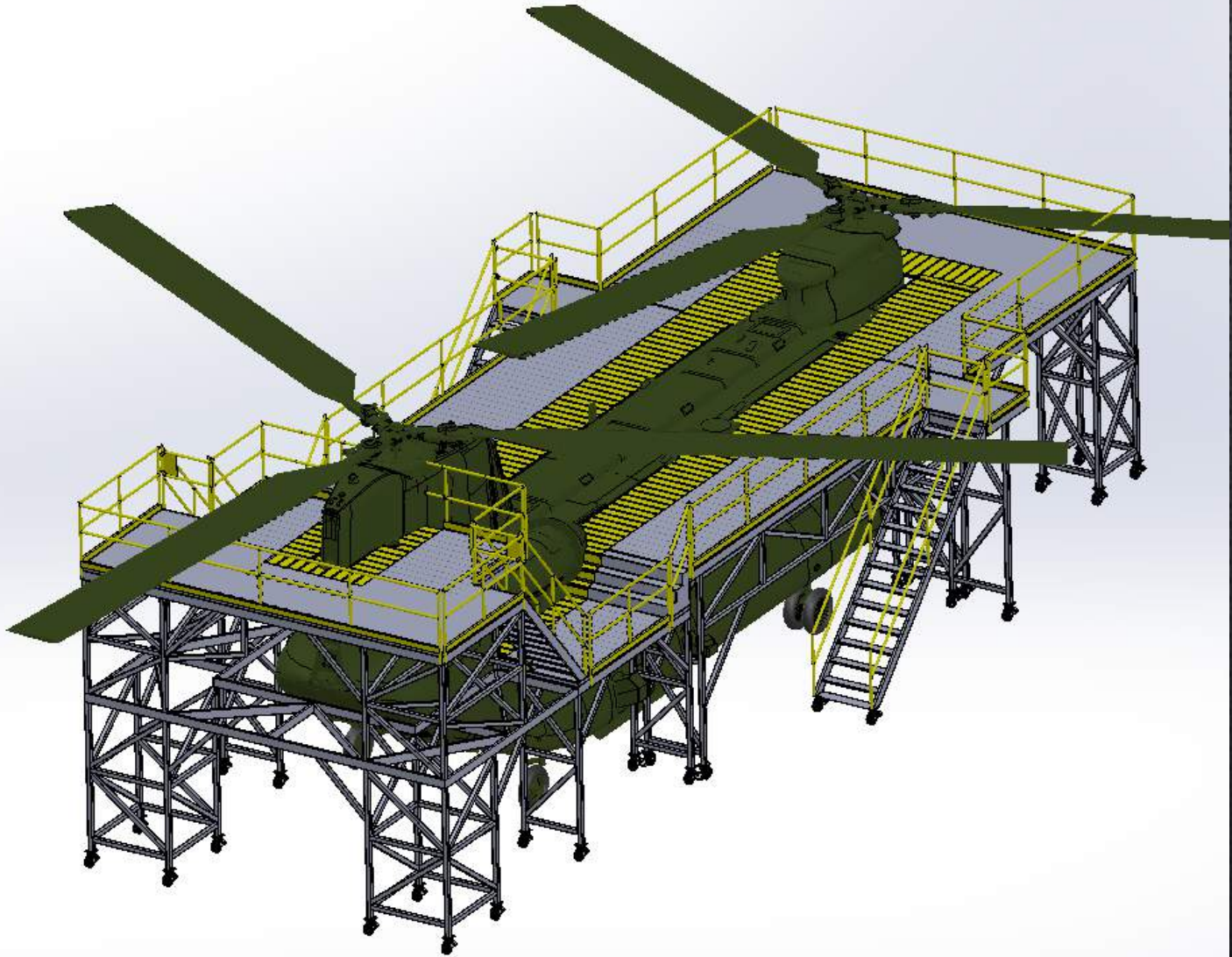

CH-47 CHINOOK ACCESS STAIR STAND



CH-47 BLADE TRAILER

BLADE TRAILER

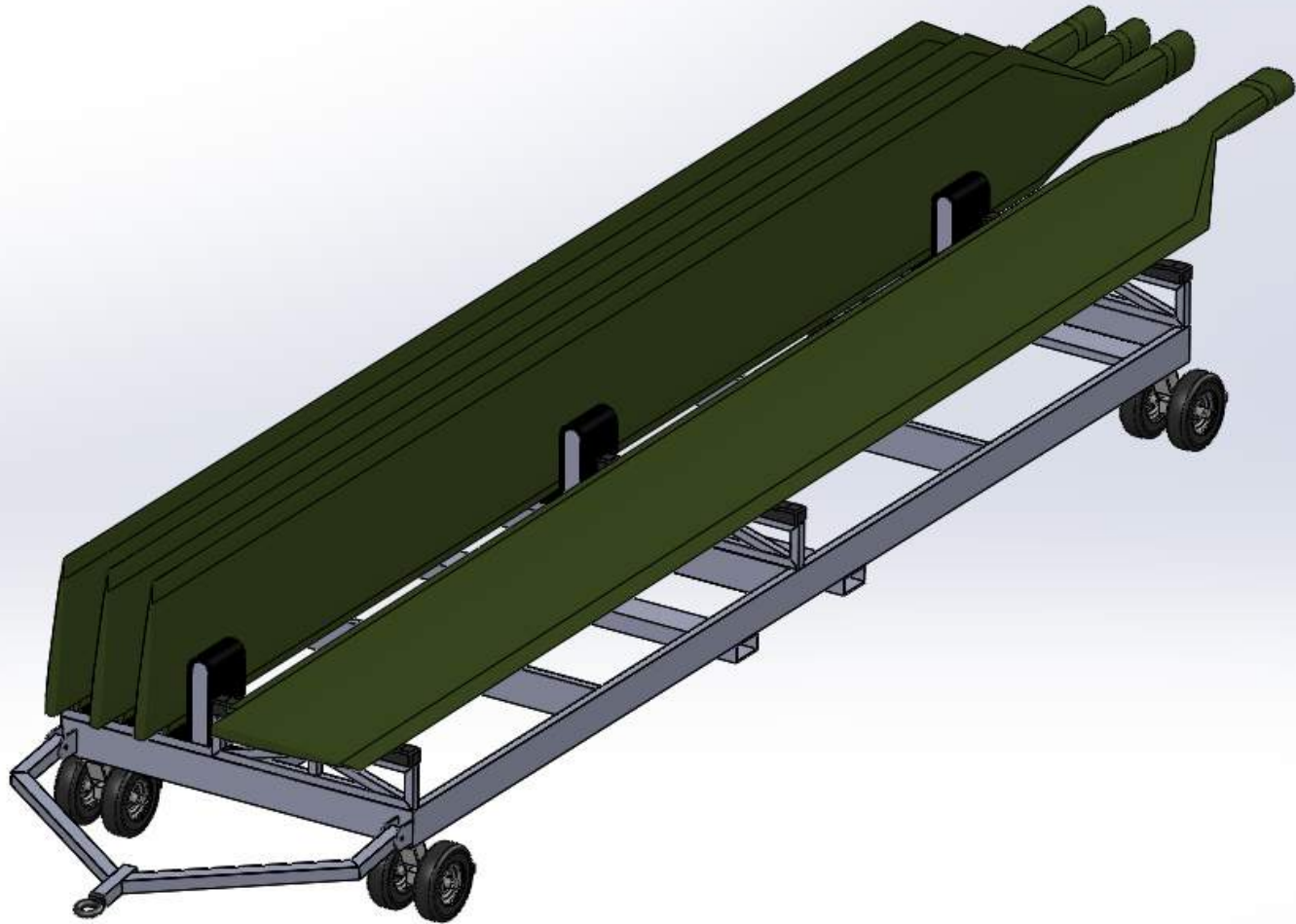

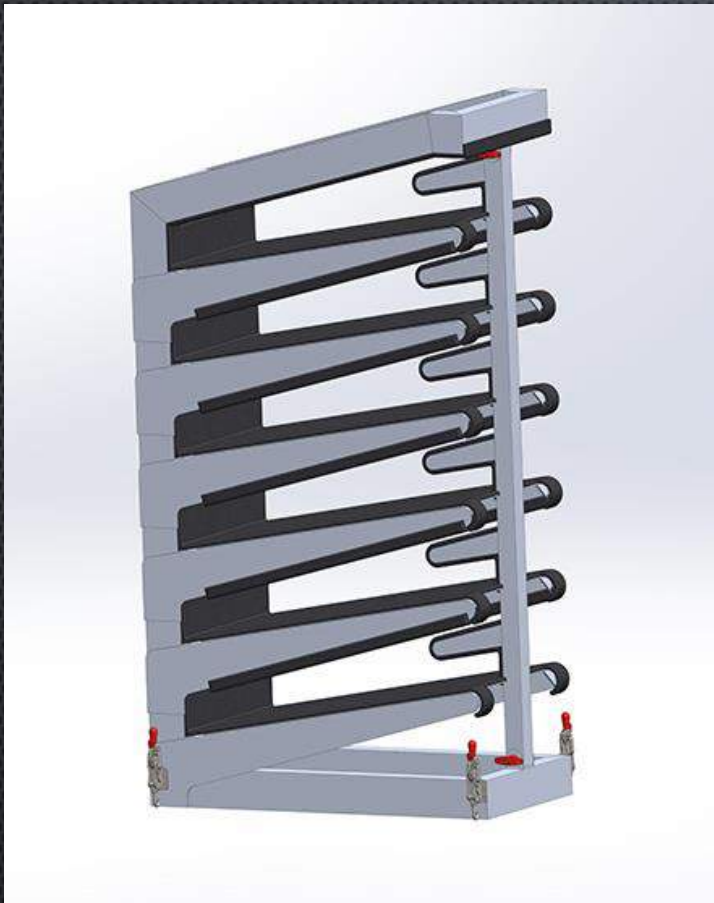

CH-47 CHINOOK Blade Transport Fixture

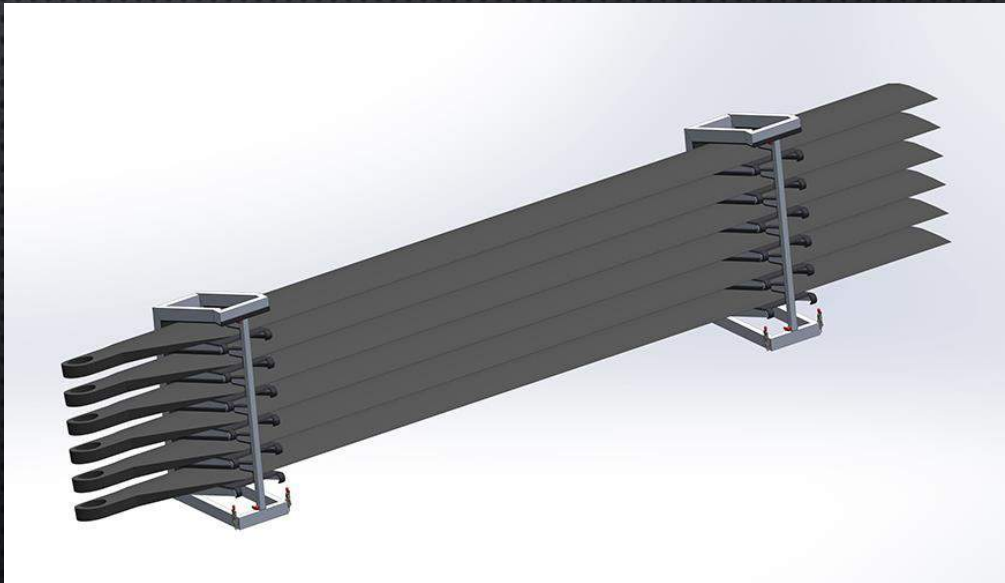

CH-47 APU Stand





AH-64
APACHE

AH-64 Maintenance Stands

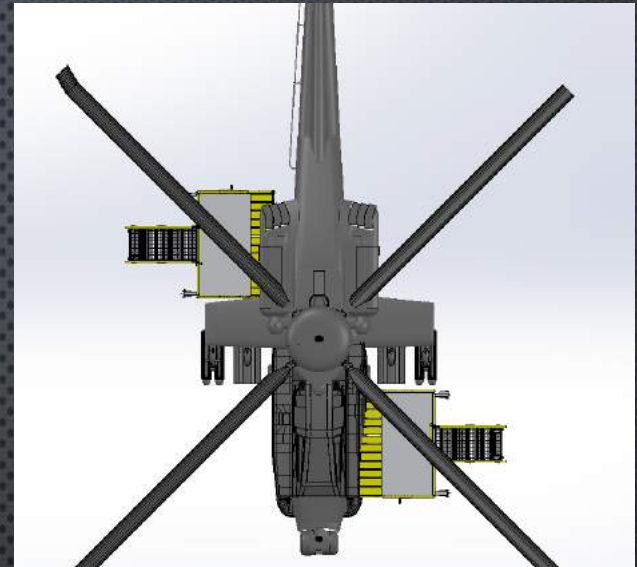

AH-64 TAIL STAND

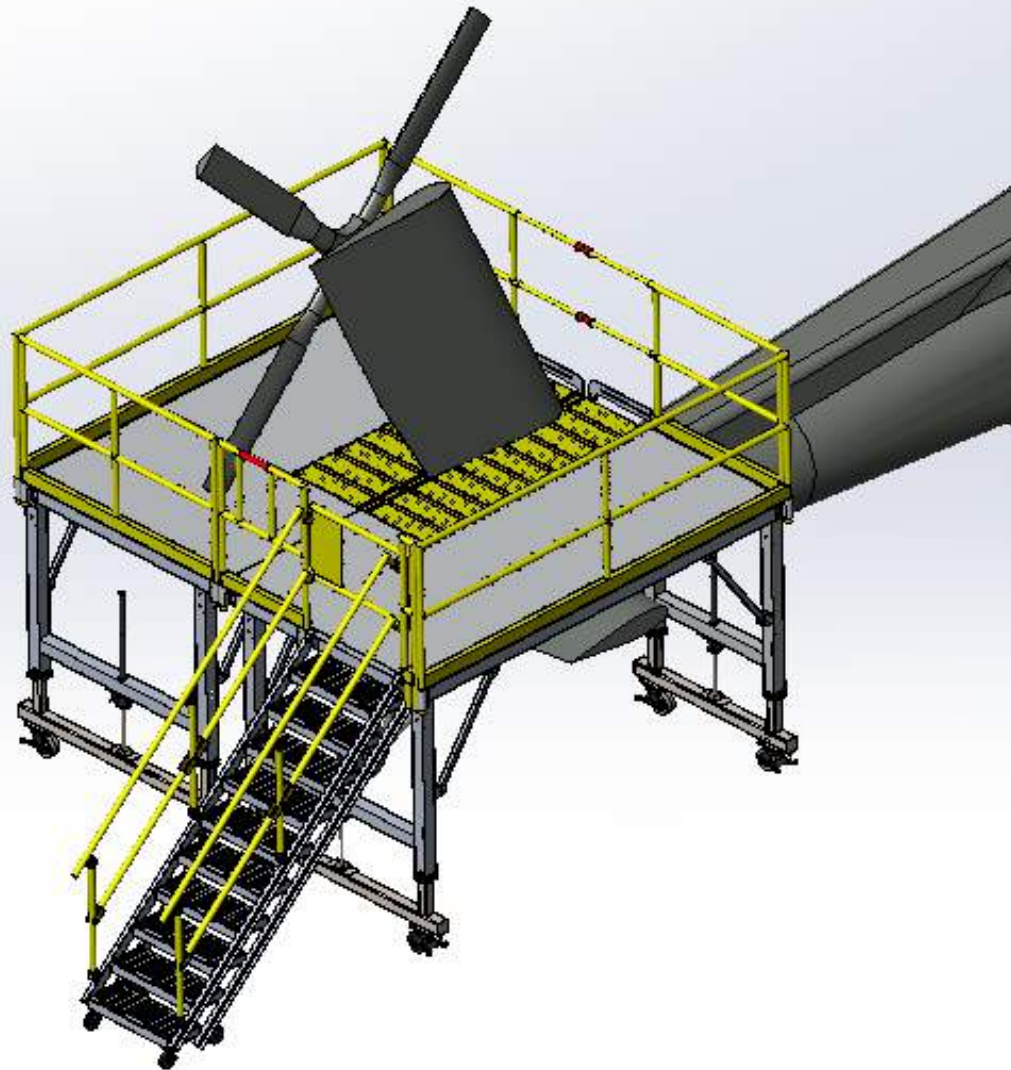



FIXED WING
MAINTENANCE STANDS

KC-135 WING, NOSE, & FUSELAGE STANDS

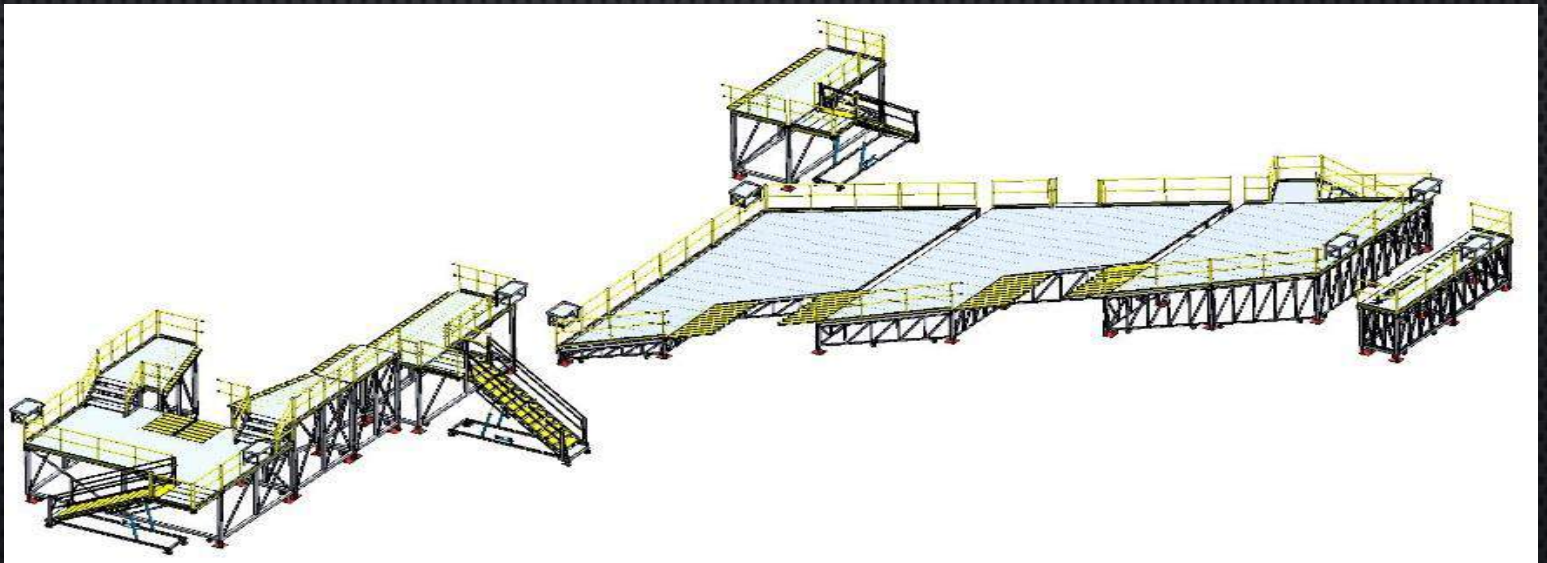
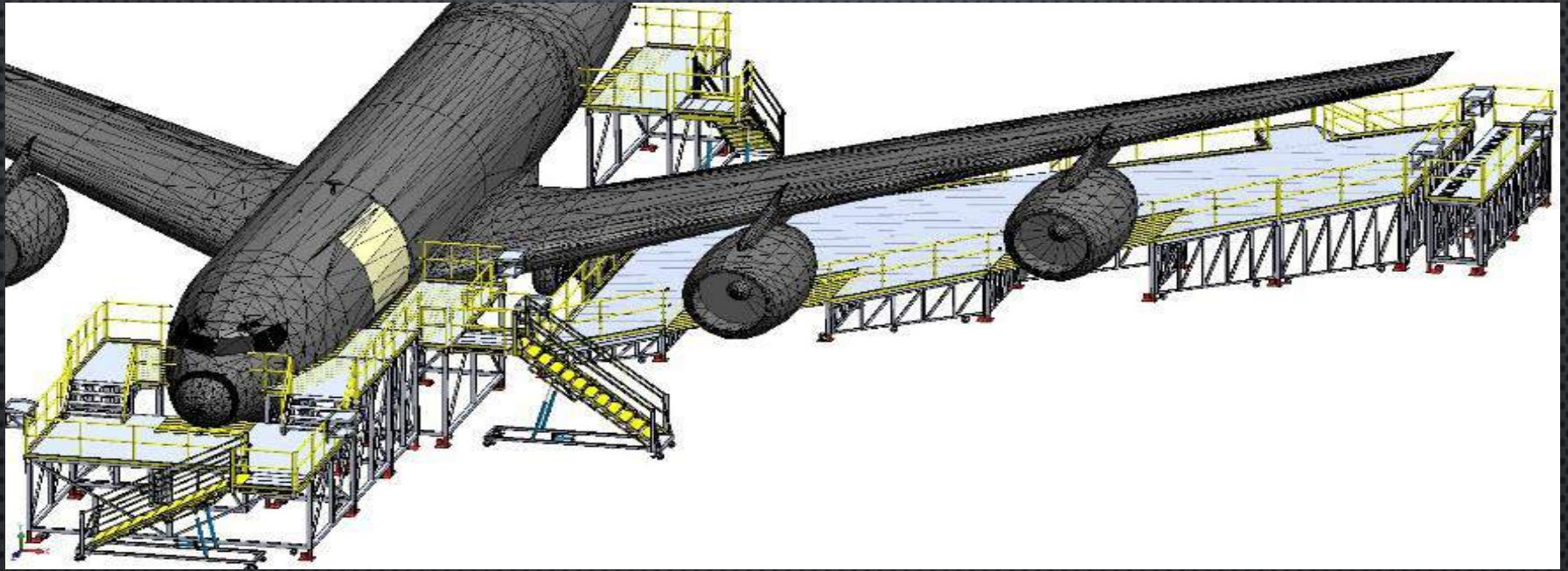

KC-135 RADOME STAND

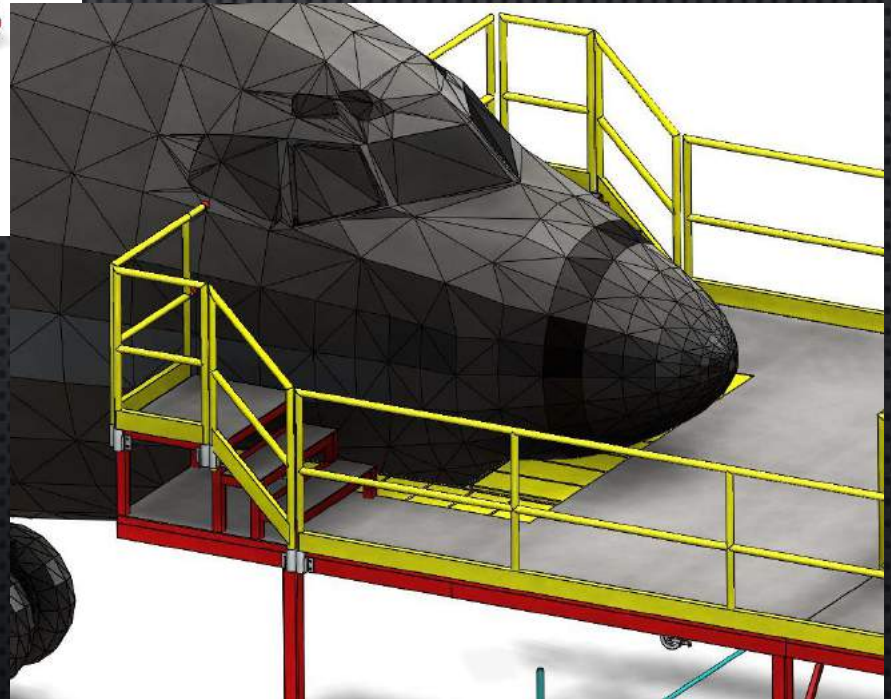
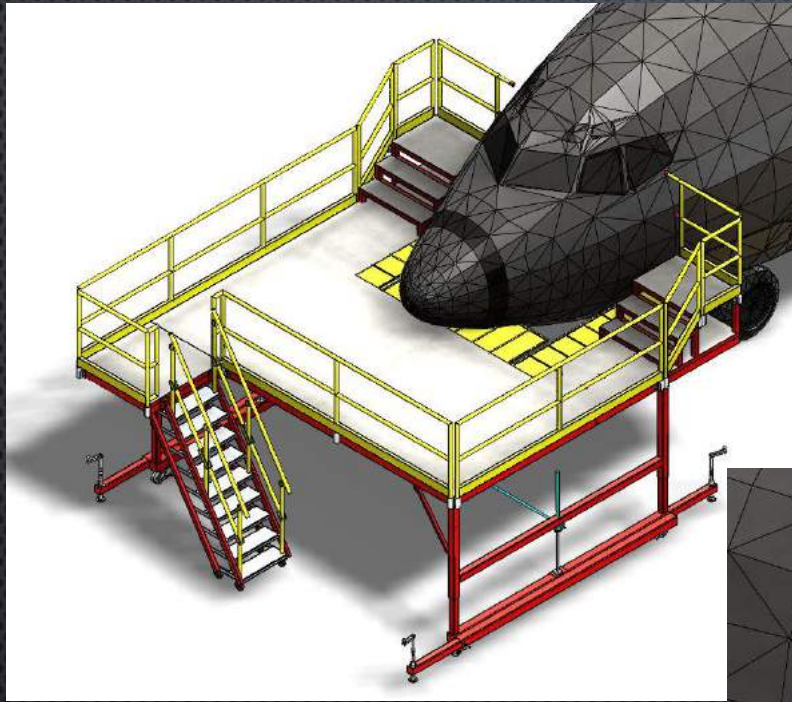

KC-135 TAIL STAND

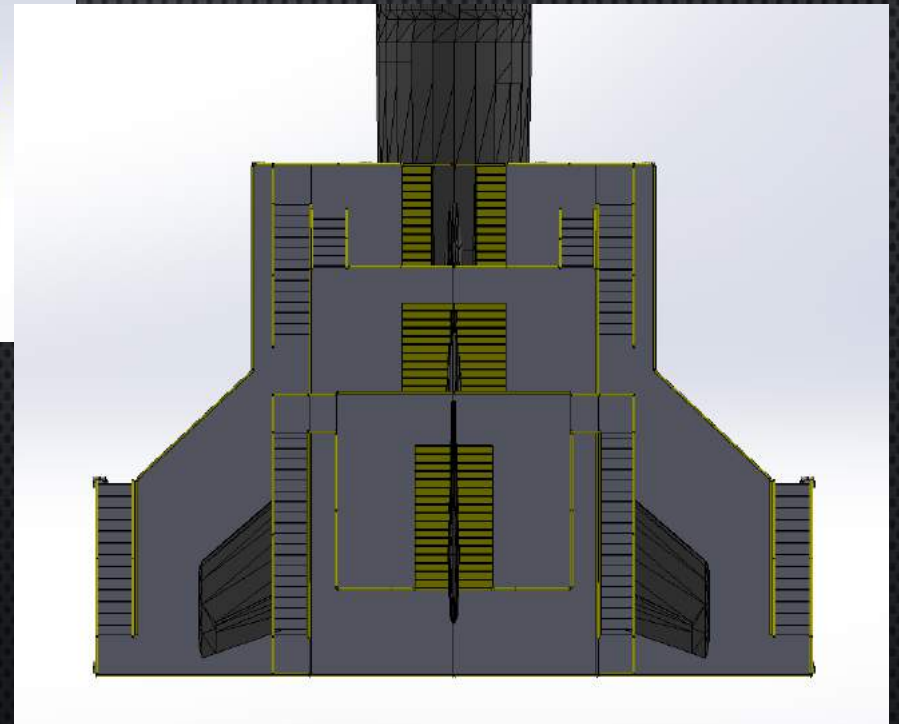
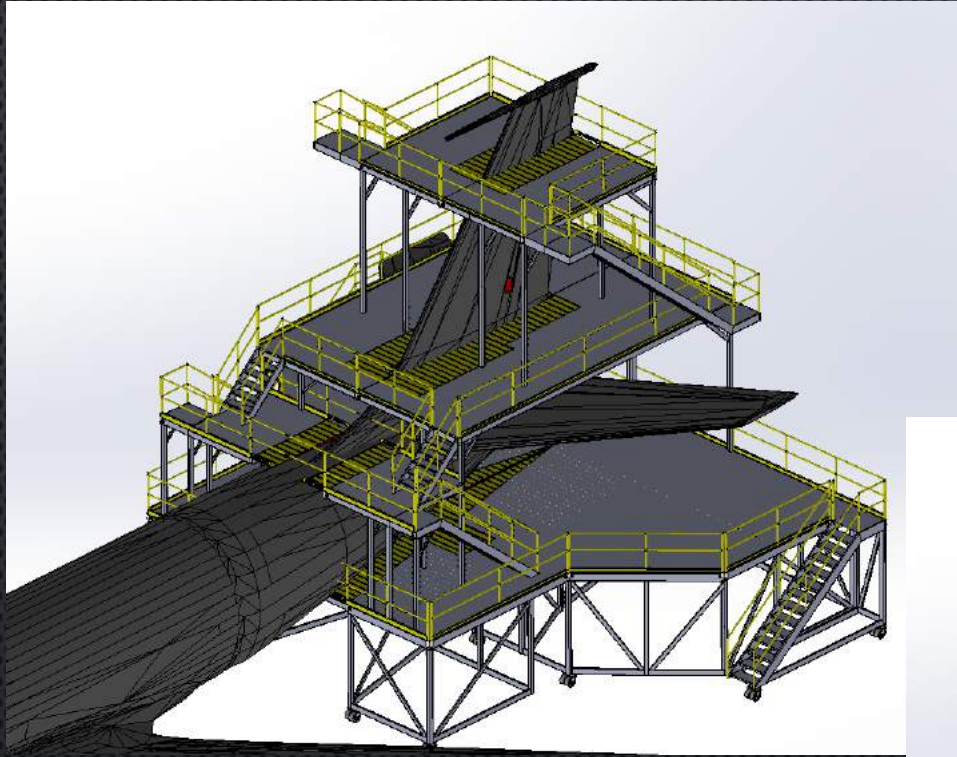

C-130 Fall Protection Stand

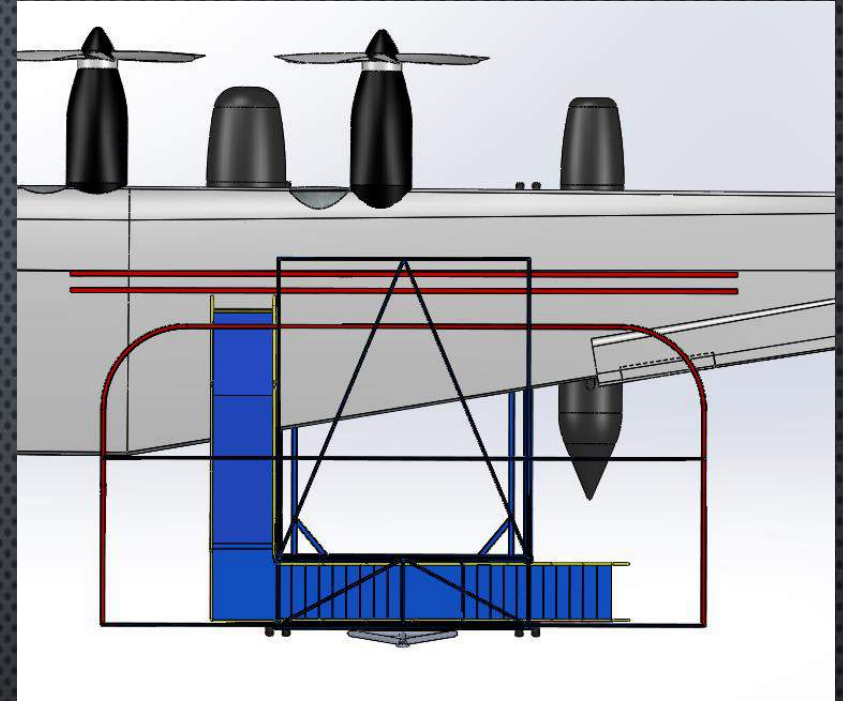
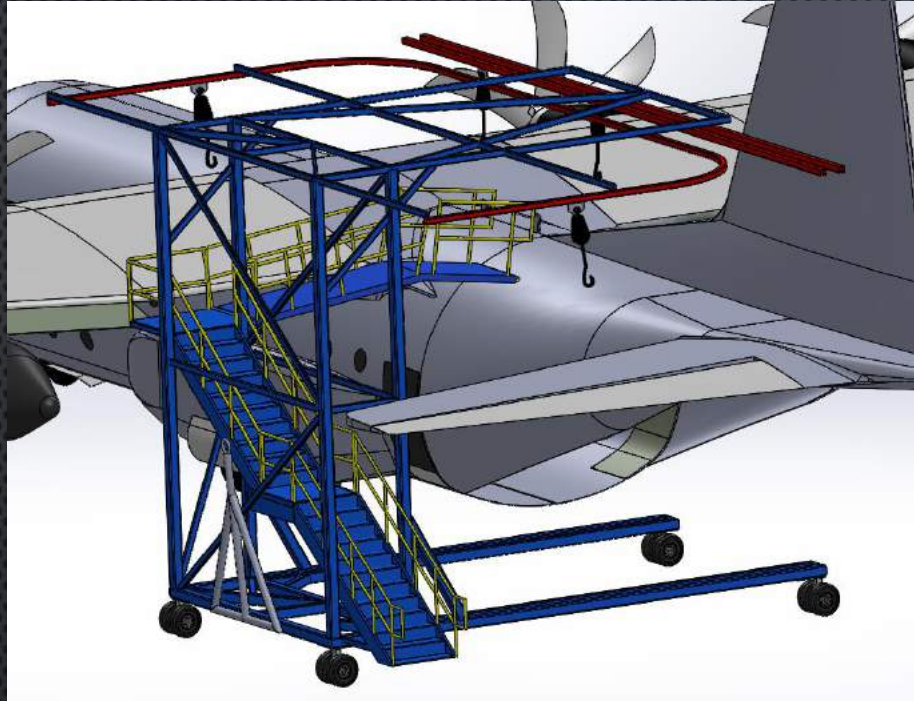

- Portable
- Use on Flight Line
- Tail, Wing, Fuselage



C-5 Engine Maintenance Stands

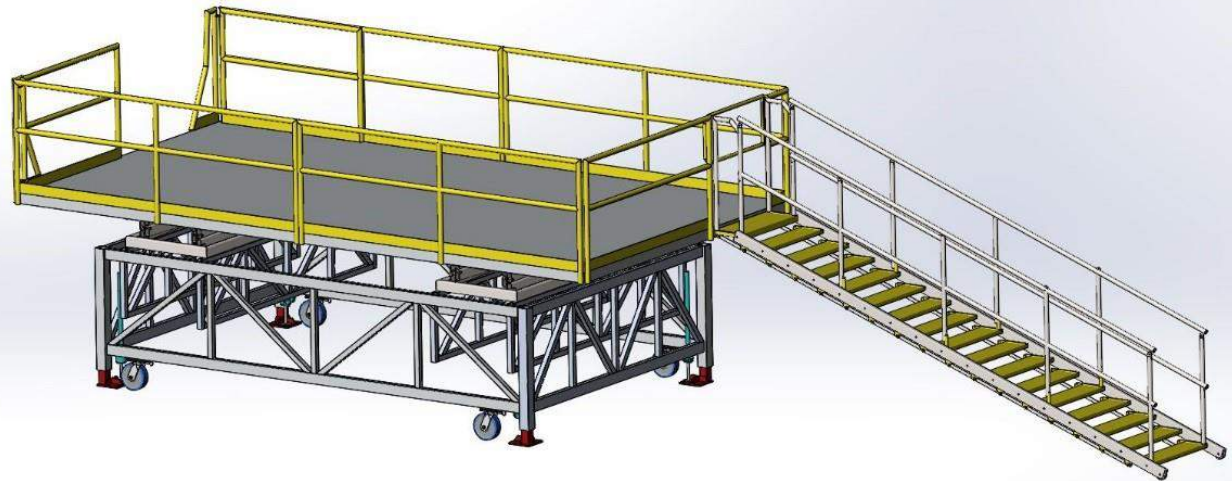
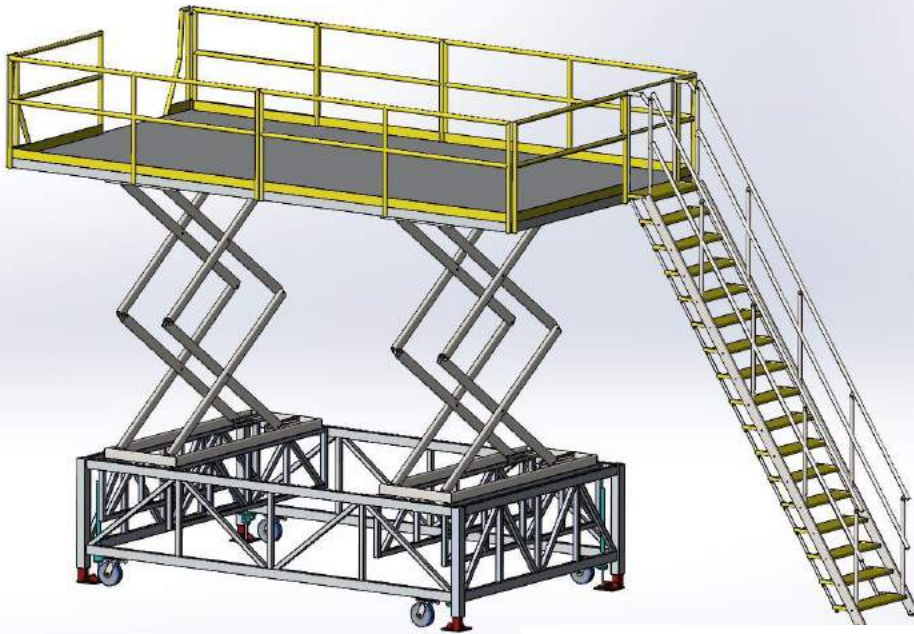

F-22 TAIL STAND

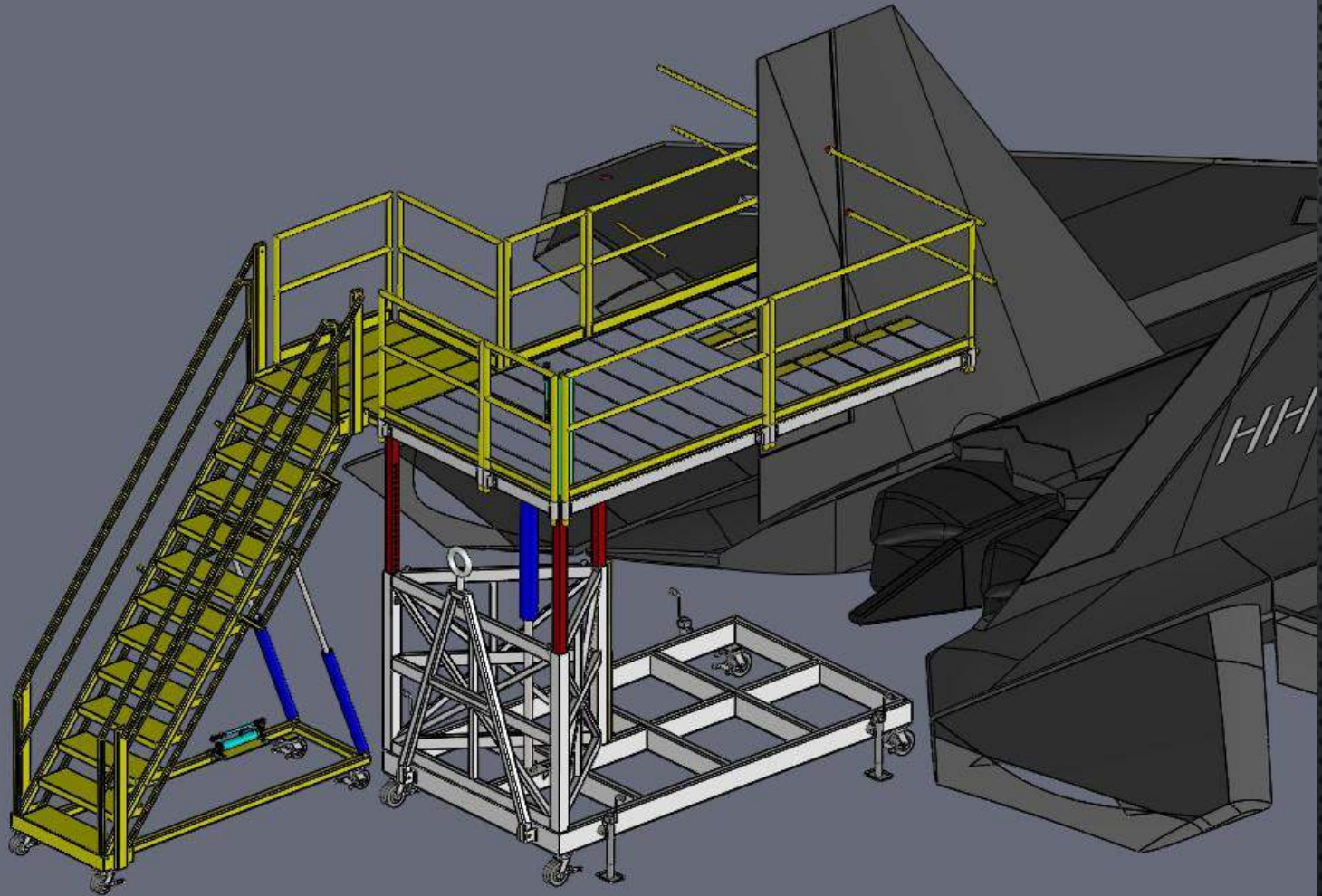

F-15 MAINTENANCE STANDS

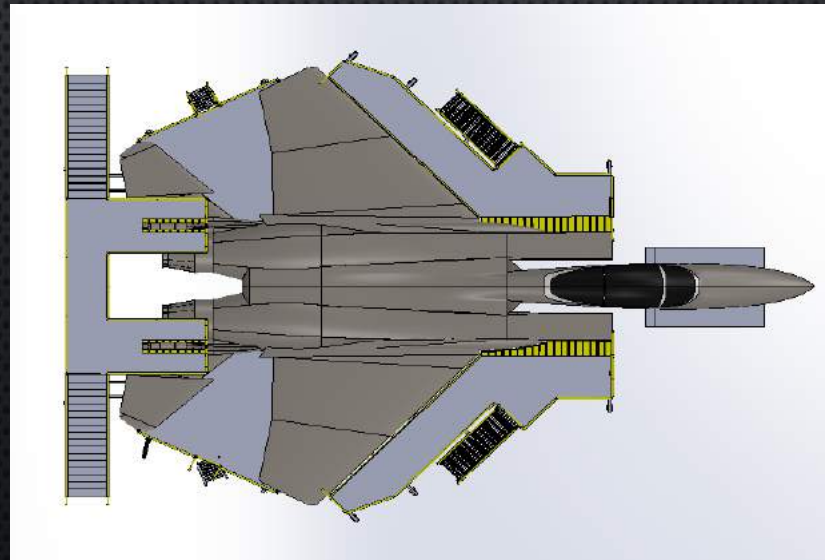
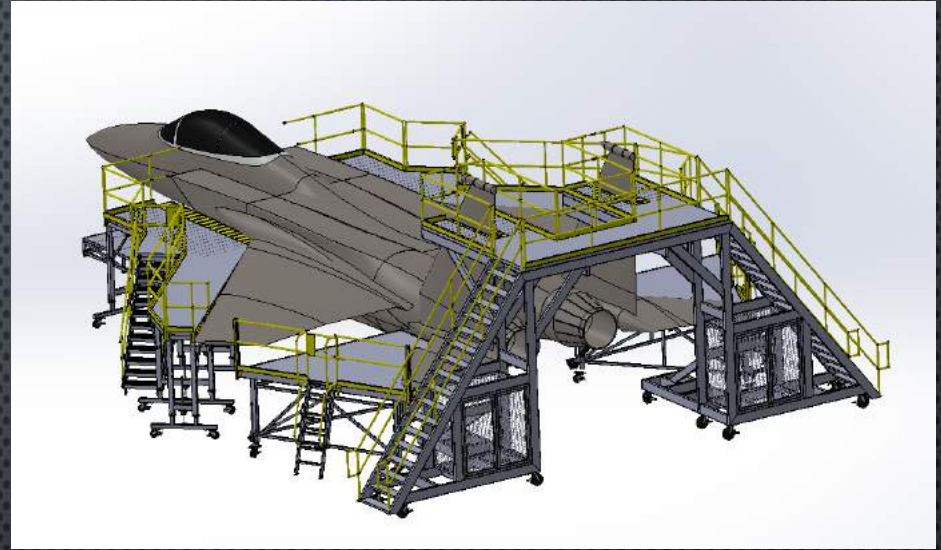
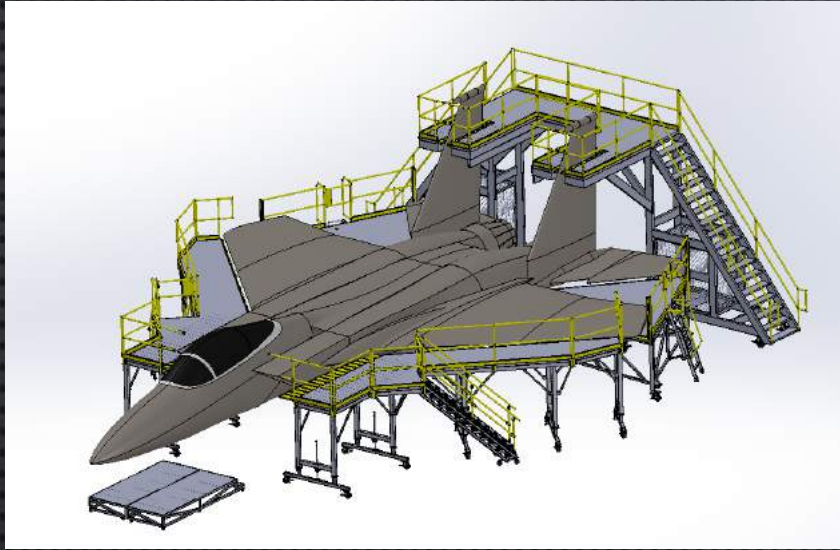

B-1 BOMBER MAINTENANCE STANDS

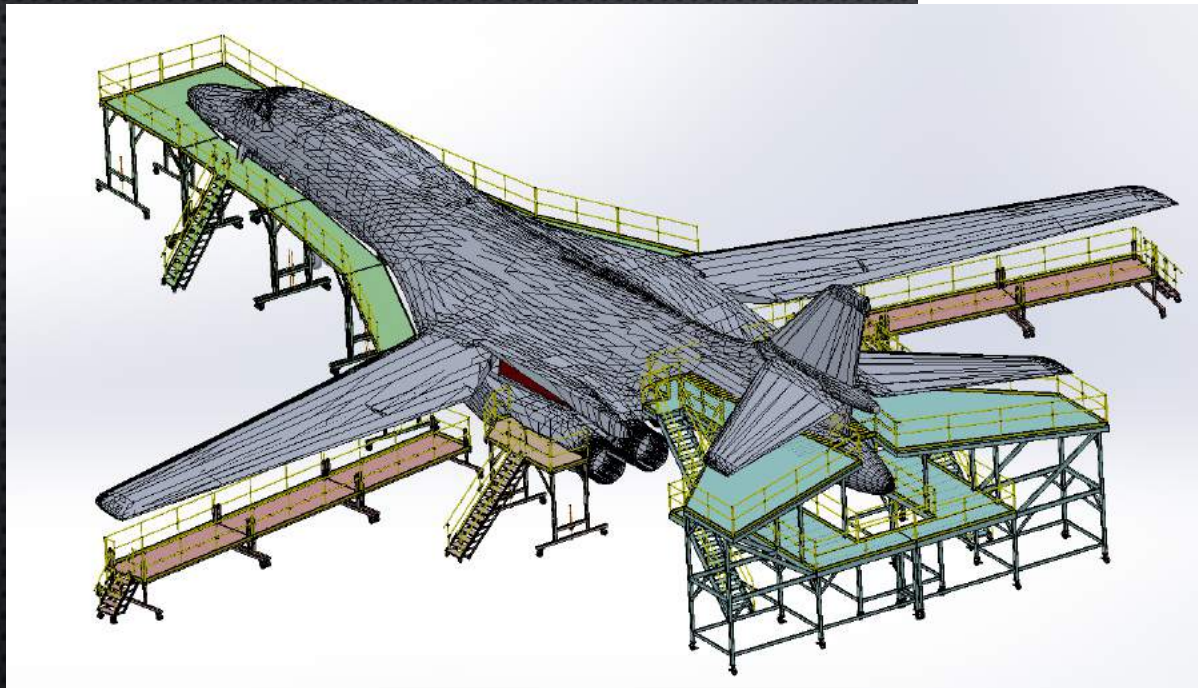
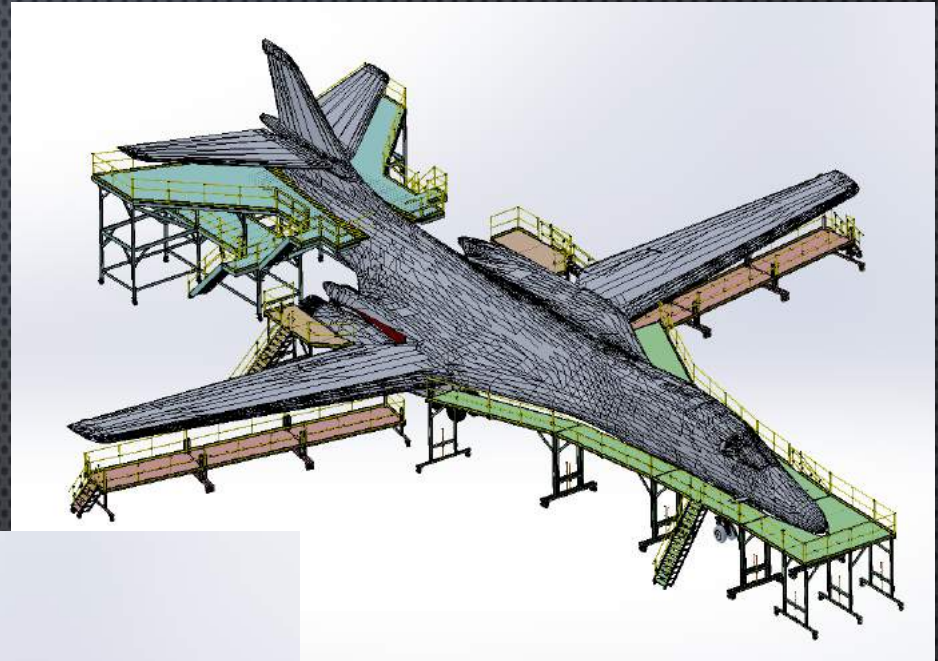
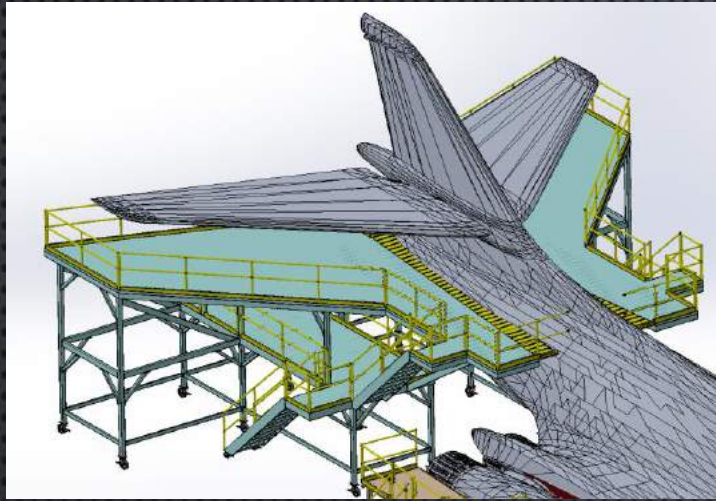

CH-53 MAINTENANCE STANDS

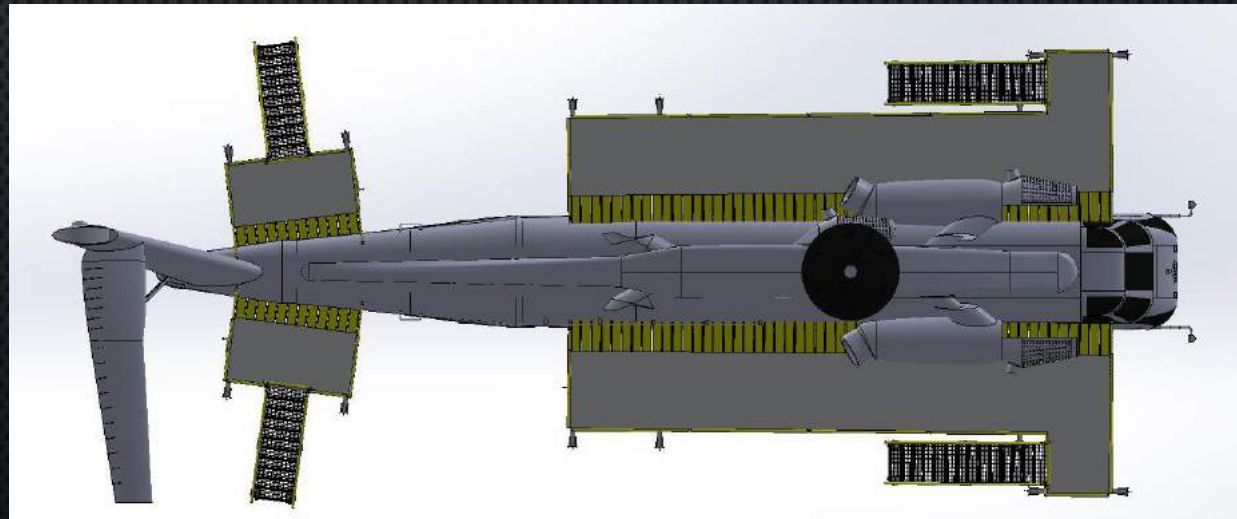
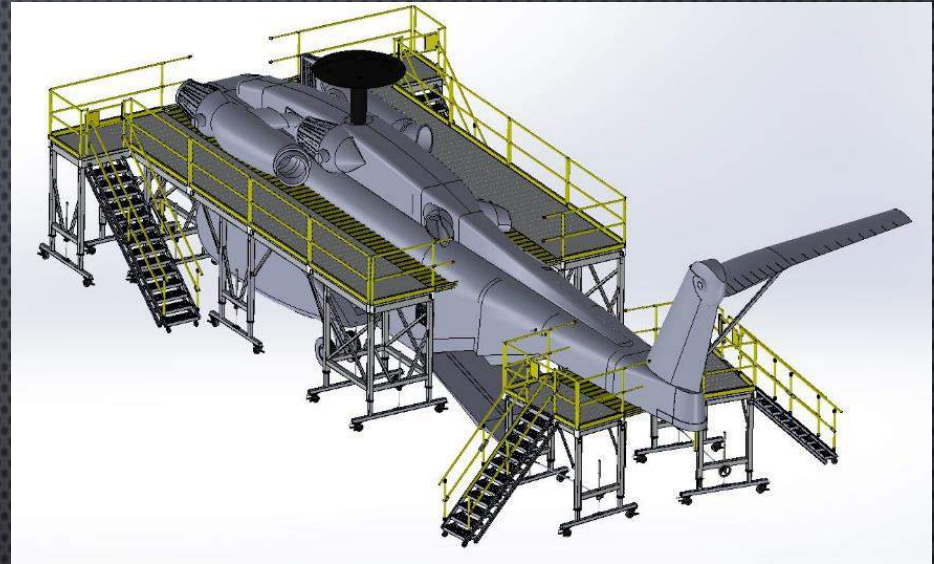

V-22 MAINTENANCE STANDS

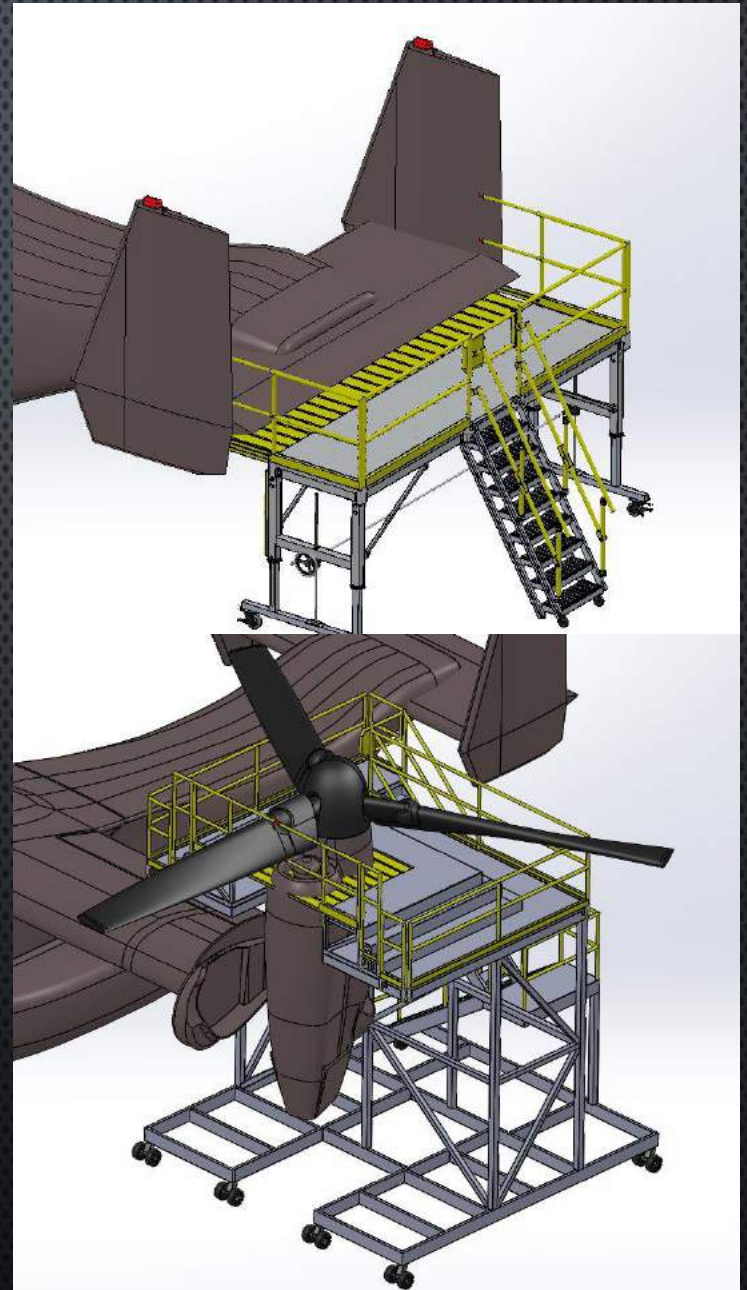
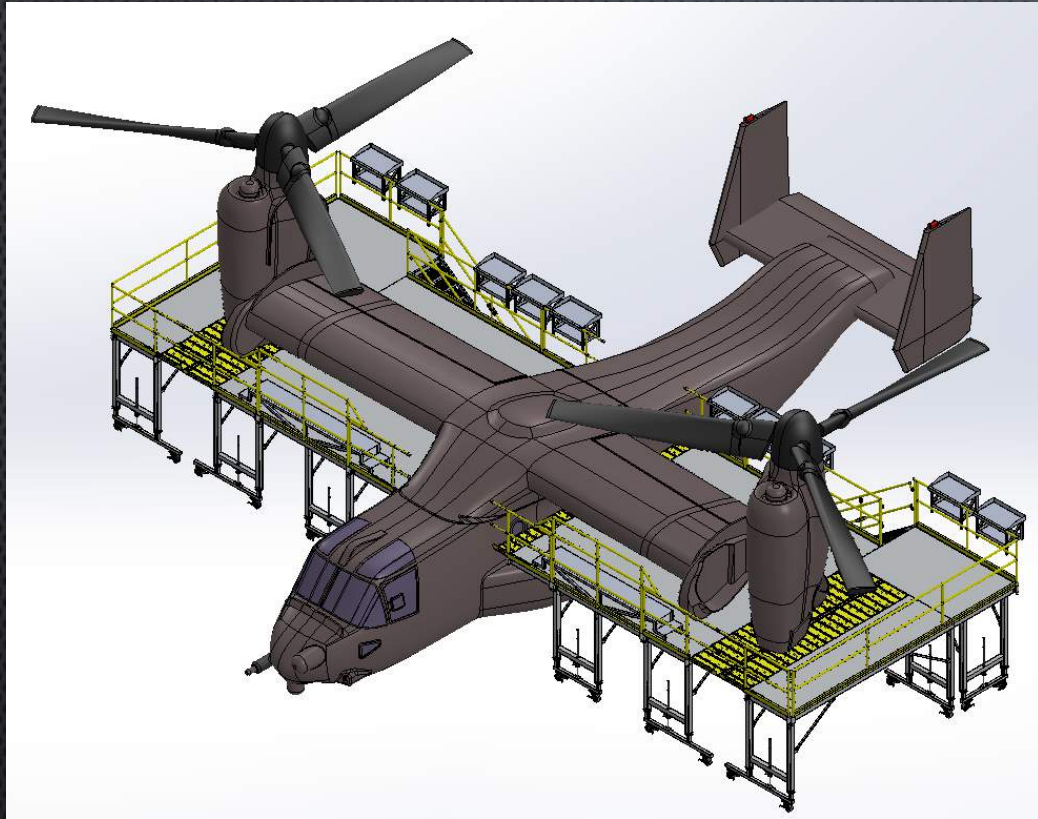

RQ7 SHADOW TRANSPORT TRAILER

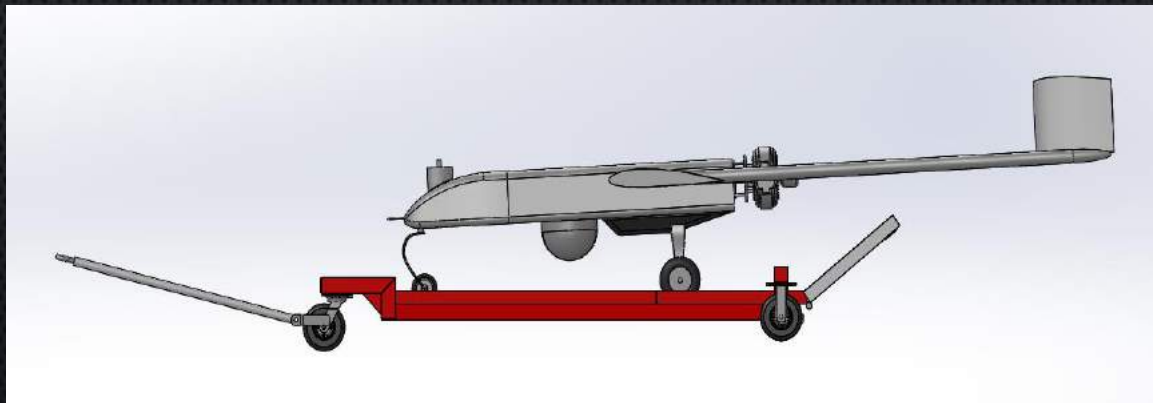
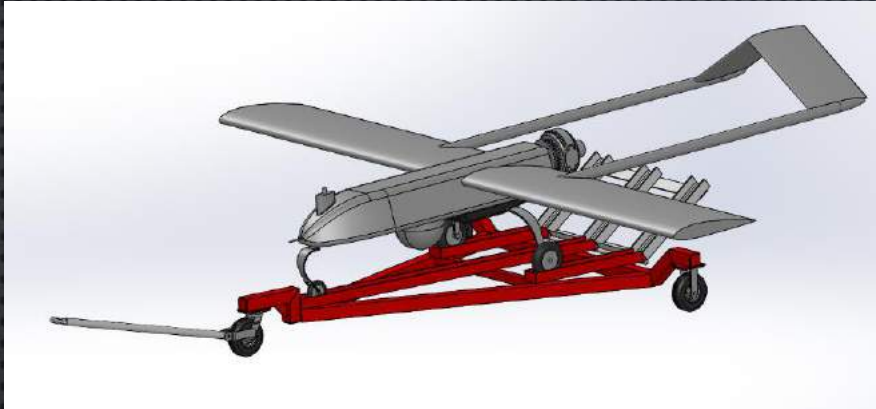

Contact Info



Cliff Hokanson
Executive VP
cliff@hhicorp.com
Office: 385-333-4400



Derek Korth
Marketing Director
derek@hhicorp.com
Direct: 385-333-4381
Cell: 801-712-2828



Kord Brown
Sales Engineer
kord@hhicorp.com
Office: 385-333-4400
Direct: 385-333-4349





THANK YOU!